

VERTICAL BLINDS

VJ030-E



Vertical blind complete system for mounting on the ceiling with mounting clips. Mounting brackets for wall mounting at an additional cost.

- 1 Top rails in matt white, natural anodized, window grey or matt black
- 2 2 230 V electric motors
- 3 lower end with weighting plates

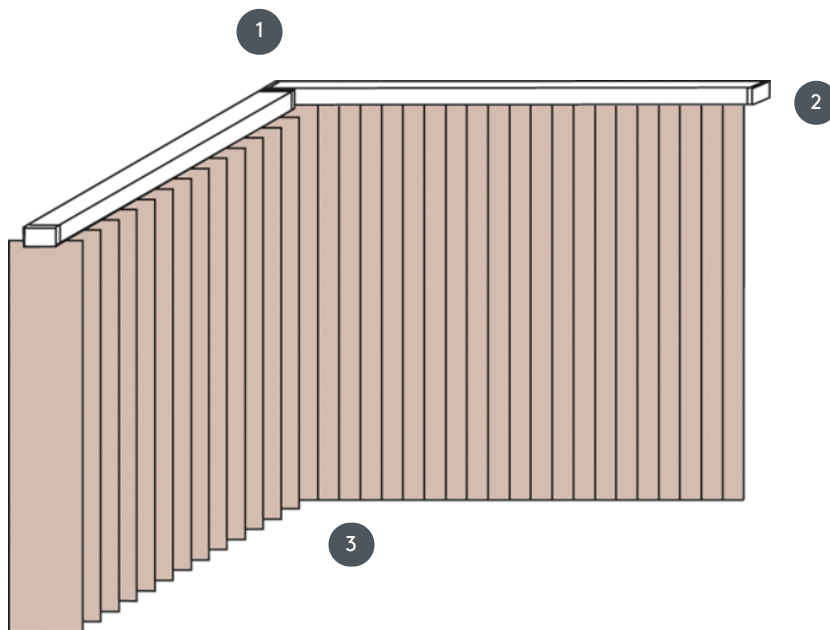

rassemblement

ceiling, wall or built-in profile

min./max. dimensions

Calculation width = total system width = width B1 + width B2 (ATTENTION please specify wall dimensions!)
Calculation height = total system heights = finished height FH1 + finished height FH2

Dimensions per finished width:

min. width 50 cm/max. width 695cm
 max. height 350 cm
 max. area 24 m²
 max. weight 22 kg

Mechanical color

matt white (RAL 9016)
 natural anodized aluminum (E6-EV1)
 Window grey structure (RAL 7040)
 matt black structure (RAL 9005)
 RAL special painting on request (at an additional charge)

waiter

Operation via 2 electric motors (230V) with integrated switch module with integrated radio receiver for bus system

EC - Declaration of Conformity in accordance with ÖNORM EN 13120:2014